

DSP150 CYCLONE SAND PLANT TECHNICAL SPECIFICATION

The DSP 150 Compact Cyclone Sandwasher is used to wash sand, recover maximum fines, and dewater sand in a modular self-contained unit. One to two grades can be produced, which are treated to meet standards such as grain size, cleanliness and consistency. This maximises saleable product and produces higher quality outputs. The range is easy to operate and proves both energy and cost efficient for sand production.

FEATURES & BENEFITS:

- High quality of fines recovery
- Both energy and cost efficient
- Maximum recovery of material above 75µm (200 mesh)
- Removes silt, slimes and clays below 75µm (200 mesh)
- Significant reduction in saleable material sent to settling pond
- Dewatering to 10–15% of residual water content

DIMENSIONS AND WEIGHT:

- Working Length – 7055mm
- Working Width – 2958mm
- Working Height – 7187mm
- Feed Height – 2015mm
- Product Discharge Height – 1335mm
- Waste Water Discharge Height – 5071mm
- Weight – 8000kg

CAPACITIES:

- Output potential up to 135tph

SUMP TANK

- Level stabilisation by floater valve
- Tank capacity – 5800 L (1278 gal)
- Feed flange, overflow pipe drain hatch, pump intake connection pipe
- Skid mounted with integrated base for motor and pump

For further info Contact Dernaseer Engineering Ltd.

Tel:+44 (0)28 8776 7646

Email : info@dernaseerwashing.com

DEWATERING SCREEN

- Dewatering screen – Length 3660mm (12') – Width 1545mm (5')
- Galvanised
- Reinforced Bolted construction
- Dewatering area 5.5m²
- Modular polyurethane sieves 1mm standard opening (other sizes available as option)
- 2 No. 7.5kW offset vibrating motors
- 8 No. High efficiency marshmallow rubber springs
- Splash protection over rear of dewatering screen
- Replaceable modular back splash panels

HYDROCYCLONE

- Rubber-lined 660mm dia. Cyclone

PUMP

- Heavy duty rubber lined slurry pump (150mm)
- IP 55 electric motor 45kW
- Rubber intake pipe with flexible connection sleeve
- Discharge pipe, reducer and elbow
- Flexible rubber pipe

ADDITIONAL SPECIFICATIONS

- Polyurethane lined front product chutes
- All necessary pipe work and fittings
- Skid mounted upper frame with walkway, handrail and access stair

OPTIONS

- Boiler box for dry feed
- Dewatering screen spray bars
- Electrical control panel

For further info Contact Dernaseer Engineering Ltd.

Tel:+44 (0)28 8776 7646

Email : info@dernaseerwashing.com

WORKING DIMENSIONS mm (in)

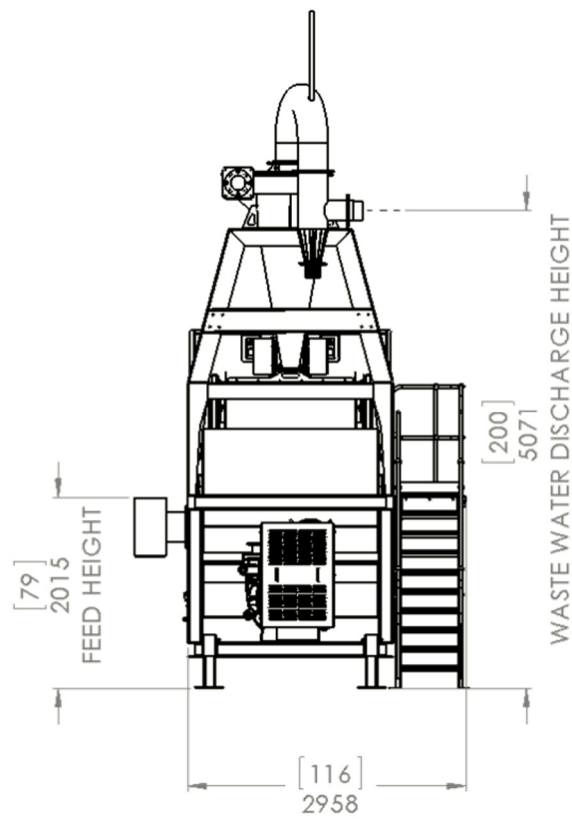
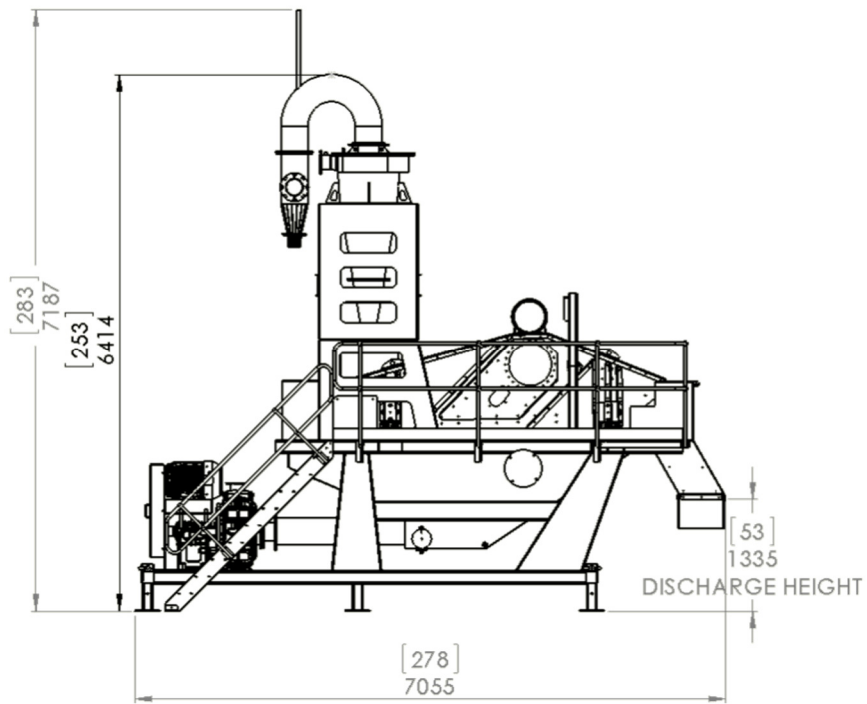

For further info Contact Dernaseer Engineering Ltd.
Tel: +44 (0)28 8776 7646
Email : info@dernaseerwashing.com



SHIPPING DIMENSIONS mm (in)

40ft Open top container

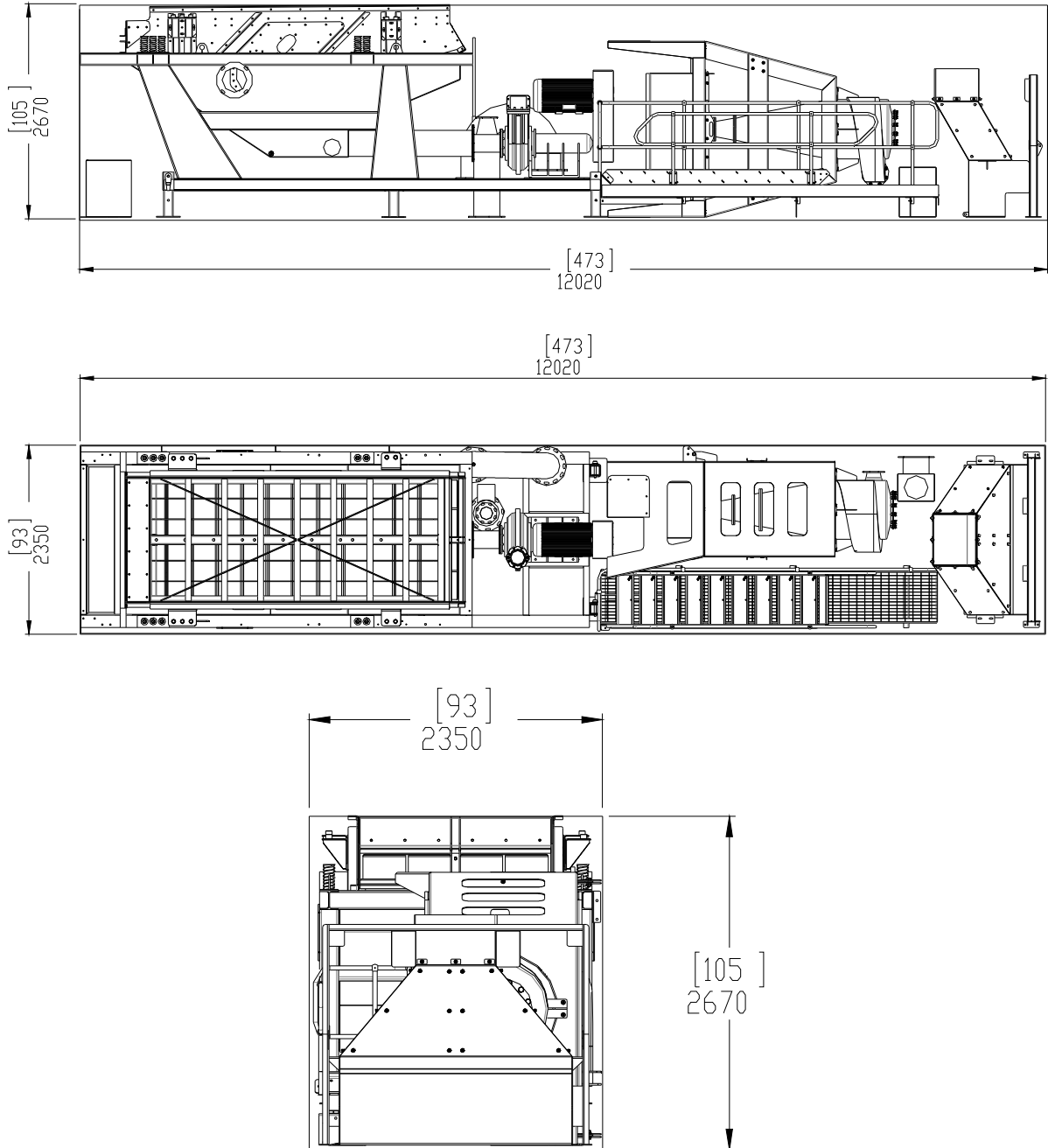

For further info Contact Dernaseer Engineering Ltd.
Tel: +44 (0)28 8776 7646
Email : info@dernaseerwashing.com